

CAPACITY	SYMBOL/ SERIAL NO.	CIRCUIT DIAGRAM
AC100~240V, 50/60Hz		
30W		

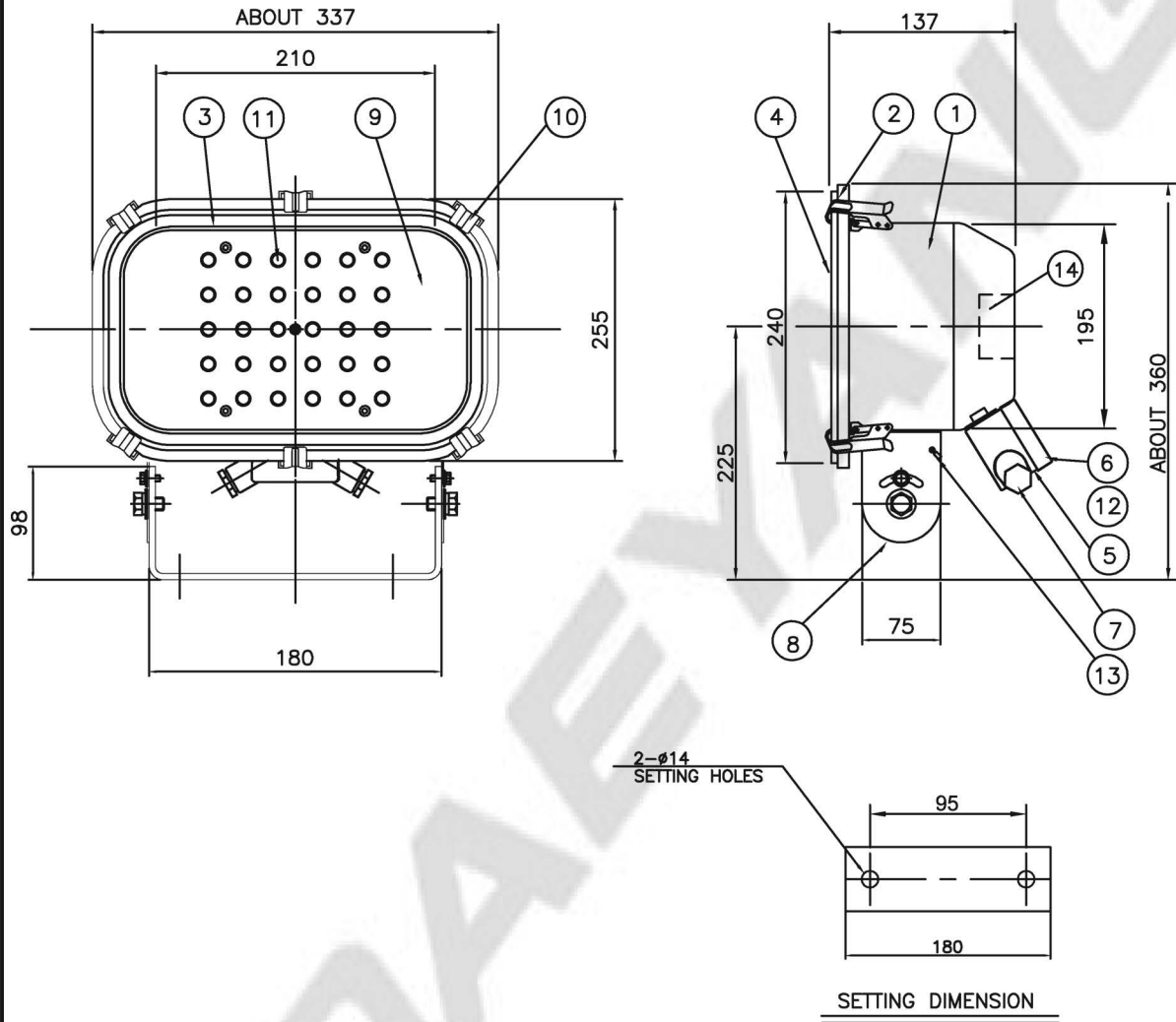

14	LED driver	-	1	DLD-48030 -PFN	7	CABLE GLAND	BRASS	1	M24xW17 (φ14~17.5)
13	OUTSIDE EARTH BOLT	STS316	1	M5	6	TERMINAL BOX COVER	PBT	1	
12	TERMINAL BLOCK	-	1	3P	5	TERMINAL BOX	PBT	1	
11	LED module	FR4	1		4	FRONT GLASS	GLASS	1	
10	LATCH	STS316	6		3	GLASS PACKING	SILICONE	1	
9	SCREEN	A1050	1		2	GLOBE FRAME	STS316L	1	
8	ARM	STS316L	1		1	BODY	STS316L	1	
NO	NAME OF PARTS	MATERIAL	Q'TY	REMARKS	NO	NAME OF PARTS	MATERIAL	Q'TY	REMARKS

APPROVED	B. K. KIM	UNIT	MM	TITLE; LED FLOOD LIGHT (30W) FOR MARINE USE					
CHECKED	J. W. PARK	SCALE	N/S						
DRAWING	H. S. SHIN	COLOR	N-9.3						
DATE	2016.02.01	IP	67						
				MODEL NO.	PF30L-550UWFC60	WEIGHT	6.1kg		
				DRAWING NO.	LR6330009	SHEET NO.	14		